

C-902B - "N" & "NC" Interlock Switches, (Types "N", "NC", N-1, N-2, N-3 and 6047), Pull Bars, Door Brackets and Hatch Door Locks

April 2, 1951

Page 1

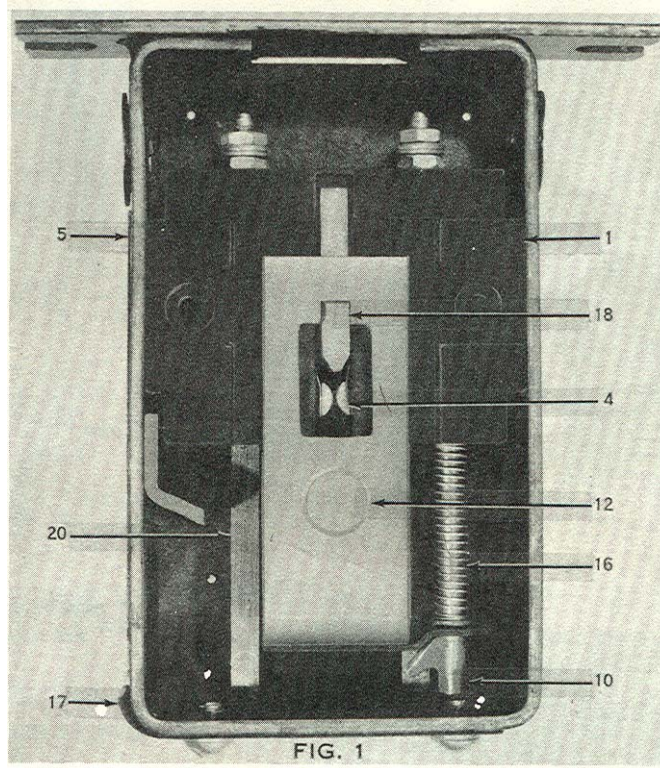

C-902B - "N" & "NC" Interlock Switches, (Types "N", "NC", N-1, N-2, N-3 and 6047), Pull Bars, Door Brackets and Hatch Door Locks

Page 2

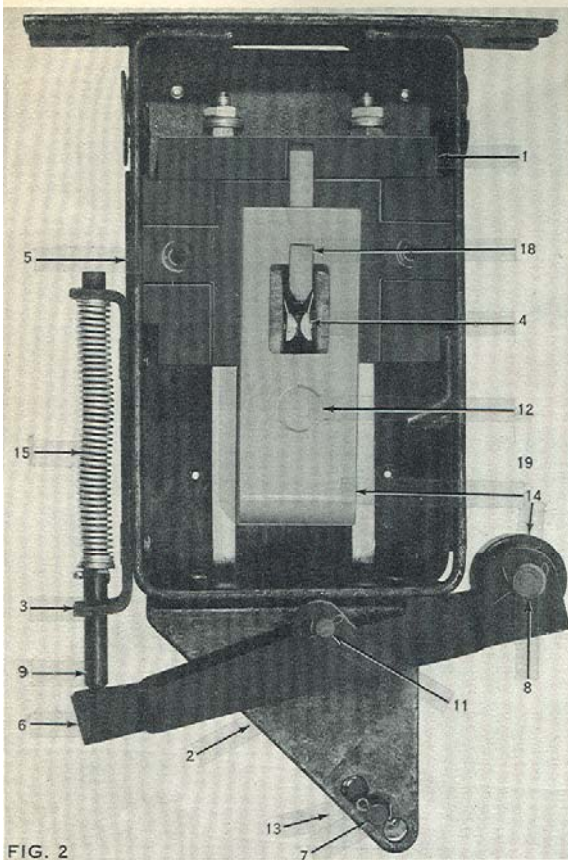

FIG. 2
A 6047A

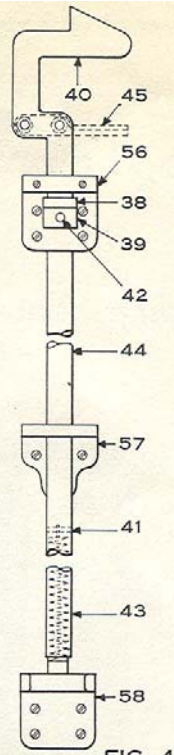

FIG. 4

Type "N"

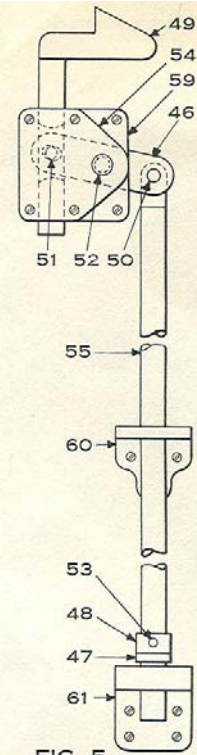

FIG. 5

Type "NC"

PULL BARS

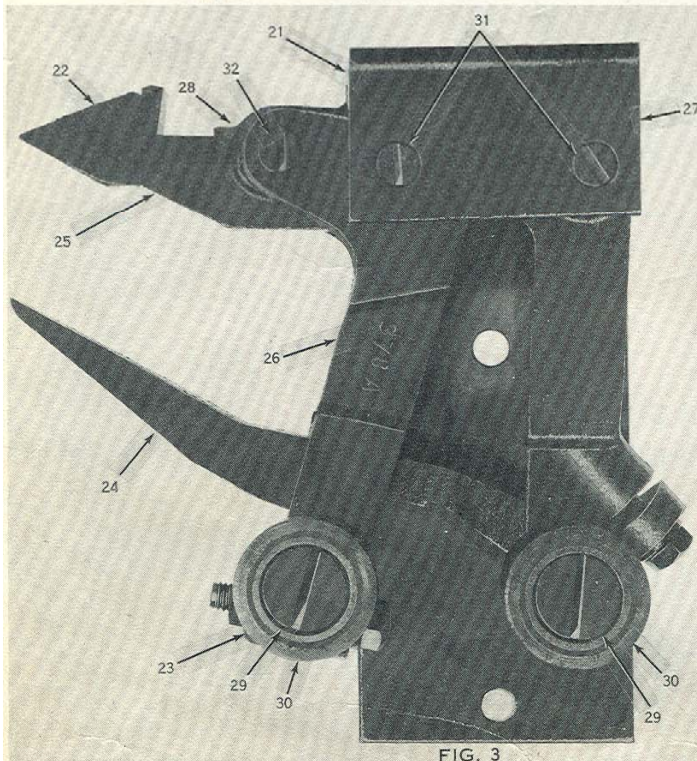

FIG. 3

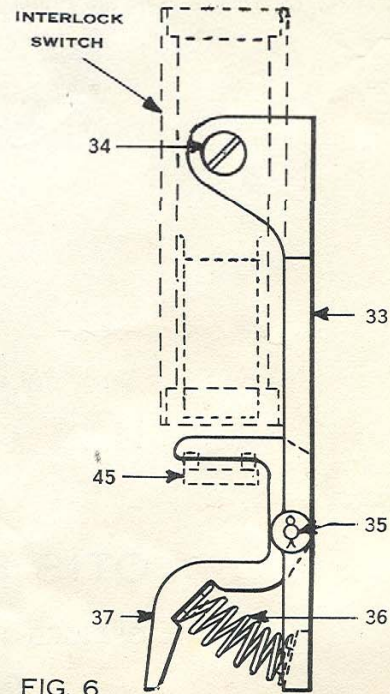

FIG. 6

Parking Key Device

**C-902B - "N" & "NC" Interlock Switches, (Types "N", "NC", N-1, N-2, N-3 and 6047),
Pull Bars, Door Brackets and Hatch Door Locks**

Page 3

MATERIAL LISTS FOR SWITCHES

582-VIII - Interlock Switch & Type "N" Pull Bars	Fig. 1-4
583-VIII - Interlock Switch & Type "NC" Pull Bars	Fig. 1-5
A6047A - N-2 Interlock Switch for Type "O" Operator	Fig. 2
A6047B - N-3 Interlock Switch for Type "O" Operator	See Note
6047C - Interlock Switch for "N" & "NC" Pull Bars	Fig. 1

PARTS FOR SWITCHES

Fig. No.	Ref. No.	Part No.	Qty	Description
1, 2	-	306EB2	2	Base, for copper Contact; not available, for replacement, order two Bases part # A306EB2
1, 2	1	A306EB2	2	Base, with silver spring Contact
2	2	316H1	1	Bracket, Catch Release
2	3	316G1	1	Bracket, Spring
1, 2	-	153P1	2	Contact, copper with connector; not available, for replacement, order two Bases part # A306EB2
1, 2	4	156A8	2	Contact, Spring, silver (for Base part # A306EB2)
1, 2	5	346FT1	2	Cover (Plate) (for Sliding Doors)
2	6	379D1	1	Lever, Spring
2	7	78C2	1	Pin, Catch Roller
2	8	79AA4	1	Pin, Roller
2	9	78D1	1	Pin, Spring
1	10	78T9	1	Pin, Spring
2	11	78C1	1	Pin, Spring Lever Hinge
1, 2	12	77CP1	1	Pin, Wedge Lifting
1	5	168856	2	Plate, Cover, with conduit nipple (for Swing Doors)
2	13	456D1	1	Roller, Catch
2	14	456BB1	1	Roller, Spring Lever
2	15	90BB14	1	Spring, 9/32" ID, 4-3/8" long, 42 active turns
1, 2	-	90LA4	1	Spring, 11/32" OD, 1" long, 10 active turns (for Bases # 306EB2 - not used with latest bases)
1, 2	-	90TA5	1	Spring, 11/32" OD, 15/16" long, 10 active turns (for Bases # 306EB2 - not used with latest bases)
1	16	90LA8	1	Spring, 5/16" OD, 2-3/4" long, 22 active turns
1	17	477AN1	1	Stop
1, 2	18	487H1	1	Wedge, only, of composition
2	19	487J1	1	Wedge, complete
1	20	487J2	1	Wedge, complete

NOTE: Type N-3 Interlock Switch (known as the "California Type") no longer available; for replacement of complete Switch, order Type N-2, Fig. 2.

C-902B - "N" & "NC" Interlock Switches, (Types "N", "NC", N-1, N-2, N-3 and 6047), Pull Bars, Door Brackets and Hatch Door Locks

PARTS FOR HATCH DOOR LOCK (FIG. 3)
ML 6045A, A6045A & B6045A

Ref. No.	Part No.	Qty	Description
21	320A1	1	Bumper, Catch Lever, 1-1/2" x 1/2", leather
22	320B1	1	Bumper, Lock, 1" x 1/2", leather
23	320C1	1	Bumper, Catch, 1-1/16" x 7/8" leather
24	331A1	1	Catch
25	379B2	1	Lever, Catch
26	379A1	1	Lever, Roller
-	379A2**	1	Lever, Roller
27*	72733	2	Nut (for Stud # 96A3)
28*	802035	1	Nut (for Stud # 96A2)
29	77A1	2	Pin (for Roller # 456C1)
29	77A2	2	Pin (for Roller # 456C2)
29	77A3	2	Pin (for Roller # 456C3)
29	77A4	2	Pin (for Roller # 456C4)
30	456C1	2	Roller, 1-9/16" face
30	456C2	2	Roller, 1-3/32" face
30	456C3	2	Roller, 1-7/32" face
30	456C4	2	Roller, 1-15/32" face
31	96A1	2	Stud, 1-1/2"-long
31	96A3	2	Stud, 1-9/16" long
32	96A2	1	Stud, 1-3/16" long
-	344G1**	1	Weight

* Arrows indicate location, the parts themselves not showing in the cut.

** Not illustrated, for California only.

PARKING KEY DEVICE (FIG. 6)

Ref. No.	Part No.	Qty	Description
OLD STYLE - ML 582-VIII-12			
33*	75898	1	Arm, Swing
34*	815319	1	Pin, Pivot, Hex. Hd.
35	79D1	1	Pin, Trigger Pivot
36	90YA20	1	Spring
37	446A1	1	Trigger
NEW STYLE - ML 6085A1			
33	288F1	1	Arm, Swing
35	79D1	1	Pin, Trigger Pivot
34	124J1	1	Screw, Pivot
36	90YA20	1	Spring
37	446A1	1	Trigger

NB Fig. 6 illustrates the new style device; the old style has the same parts, but some are slightly different.

* Arrows indicate location, the parts themselves not showing in the cut.

**C-902B - "N" & "NC" Interlock Switches, (Types "N", "NC", N-1, N-2, N-3 and 6047),
Pull Bars, Door Brackets and Hatch Door Locks**

Page 4

PARTS FOR PULL BARS

Ref. No.	Part No.	Qty	Description
FIG. 4 - FOR TYPE "N" BAR INTERLOCKS - ML 582-VIII-			
38	168881	1	Bumper, rubber
39	168882	1	Ferrule
40	168883	1	Head, Locking, steel
40	181442*	1	Head, Locking, steel
41	80635	1	Pin
42	80648	1	Pin (for Ferrule)
-	168880	1	Pull Bar, complete, with steel Locking Head, less brackets
-	181440*	1	Pull Bar, complete, with steel Locking Head and Extension Yoke, less brackets
43	813509	1	Spring, Compression (for Tube)
44	168884	1	Tube (Rod)
45	492A1*	1	Yoke, Extension
FIG. 5 - FOR TYPE "NC" BAR INTERLOCKS - ML 583-VIII-			
46	168875	1	Arm, Rocker, complete
59	178550	1	Bracket, Top (H= 13/16")
59	178551	1	Bracket, Top (when H= 1-1/4" or 1-7/8")
47	168881	1	Bumper, rubber
48	168882	1	Ferrule
49	168877	1	Head, Locking (bronze)
49	168878	1	Head, Locking (steel)
50	813503	1	Pin
51	813504	1	Pin
52	813505	1	Pin (for Bracket #178550)
52	813506	1	Pin (for Bracket #178551)
53	80648	1	Pin (for Ferrule)
54	168879	1	Plate, Cover (for Top Bracket)
-	168871	1	Pull Bar, complete, with steel Locking Head, less intermediate & bottom brackets (H=13/16")
-	168876	1	Pull Bar, complete, with bronze Locking Head, less intermediate & bottom brackets (H=13/16")
-	169579	1	Pull Bar, complete, with steel Locking Head, less intermediate & bottom brackets (when H= 1-1/4" or 1-7/8")
55	178552	-	Rod, Pull, complete with Bumper and Ferrule

* For Parking Key Device

C-902B - "N" & "NC" Interlock Switches, (Types "N", "NC", N-1, N-2, N-3 and 6047), Pull Bars, Door Brackets and Hatch Door Locks

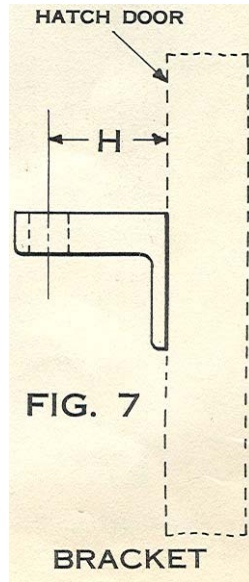

PULL BAR BRACKETS

Part Number			Qty	Bracket Fig. 7 H=	Type of Door
Top Ref. No. 56	Intermediate Ref. No. 57	Bottom Ref. No. 58			
FOR TYPE "N" BAR INTERLOCKS - FIG. 4					
168897	168891	168903	1	13/16"	Slide
168897	168888	168903	1	13/16"	Slide & Swing
168915	168892	168904	1	1-1/4"	Slide; Sgl. & Dbl. Swing
168915	168889	168904	1	1-1/4"	Slide & Swing
168916	168893	168905	1	1-7/8"	Slide
168916	168890	168905	1	1-7/8"	Slide & Swing
FOR TYPE "NC" BAR INTERLOCKS - FIG. 5					
Ref. No. 59	Ref. No. 60	Ref. No. 61			
178550	168891	168907	1	13/16"	Slide; Swing
178550	168888	168907	1	13/16"	Slide & Swing
178551	168892	168908	1	1-1/4"	Slide; Sgl. & Dbl. Swing
178551	168889	168908	1	1-1/4"	Slide & Swing
178551	168893	168909	1	1-7/8"	Slide
178551	168890	168909	1	1-7/8"	Slide & Swing

NB "Slide" includes Single Slide, Center Opening and Two-Speed Doors.